

### SPECIFICATIONS

**CONTACT RATING:** Dependent upon contact material See Page 69.

**MECHANICAL LIFE:** 30,000 make-and-break cycles.

**CONTACT RESISTANCE:** 20 mΩ max. initial @ 2-4VDC  
100mA for both silver and gold plated contacts.

**INSULATION RESISTANCE:** 1,000 MΩ min.

**DIELECTRIC STRENGTH:** 1,000 Vrms min. @sea level.

**OPERATING TEMPERATURE:** -30°C to 85°C.

### MATERIALS

**CASE:** Diallyl phthalate (DAP) (UL94v-0).

**ACTUATOR:** Nylon, black std.

**BUSHING:** Brass or Zinc, nickel plated.

**HOUSING:** Stainless Steel.

**SWITCH SUPPORT:** SUS or Brass, tin plated.

**TERMINAL/CONTACT:** Copper alloy or Brass, with silver or gold plated. (See Page 69)



4M  
Rocker Switches

## HOW TO ORDER

MODEL NO.    ACTUATOR    ACTUATOR COLOR    ACTUATOR MARKING    TERMINATIONS    TERMINAL PLATING    SEAL    RoHS SOLDERING

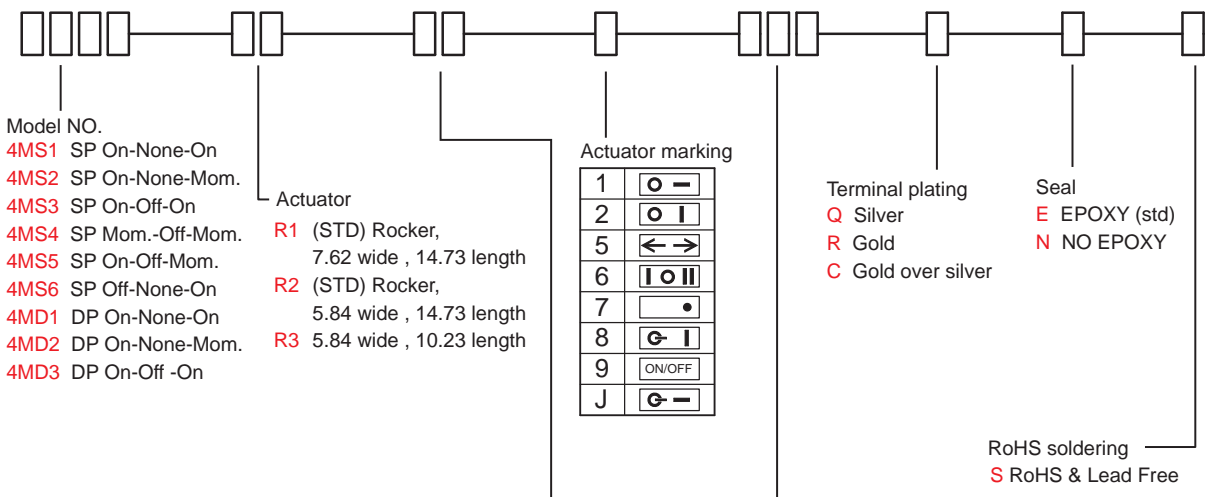

- Model NO.
- 4MS1 SP On-None-On
  - 4MS2 SP On-None-Mom.
  - 4MS3 SP On-Off-On
  - 4MS4 SP Mom.-Off-Mom.
  - 4MS5 SP On-Off-Mom.
  - 4MS6 SP Off-None-On
  - 4MD1 DP On-None-On
  - 4MD2 DP On-None-Mom.
  - 4MD3 DP On-Off -On

- Actuator
- R1 (STD) Rocker, 7.62 wide , 14.73 length
  - R2 (STD) Rocker, 5.84 wide , 14.73 length
  - R3 5.84 wide , 10.23 length

Actuator marking

1	○ —
2	○
5	← →
6	○
7	— •
8	⊕
9	ON/OFF
J	⊕ —

Actuator color

ITEM NO	COLOR
01	White
02	Black (Std)
03	Red
04	Orange
05	Yellow
06	Green
07	Blue
08	Brown
09	Gray

\* Besides standard color, other colors need to check stocks available.

- Terminal plating
- Q Silver
  - R Gold
  - C Gold over silver
- Seal
- E EPOXY (std)
  - N NO EPOXY

RoHS soldering

- S RoHS & Lead Free

- Terminations
- M1 Solder Lug
  - M2 PC thru-hole
  - M5 wire wrap
  - M6 Right angle, PC thru-hole
  - M6N Right angle, snap-in, PC thru-hole
  - M7 Vertical right angle, PC thru-hole
  - M7N Vertical right angle, snap-in, PC thru-hole
  - VS2 8.94 high, V-bracket
  - V2N 8.94 high, snap-in V-bracket
  - VS3 8.94 high, V-bracket
  - V3N 8.94 high, snap-in V-bracket

\* 4MS6 model type not applicable to M6/M6N/M7/M7N terminations

# 4M Series

Sub-Miniature Rocker Switches

## SWITCH FUNCTION

NO. POLES	UL/CSA MODEL NO.	MODEL NO.	SWITCH FUNCTION			CONNECTED TERMINALS / SCHEMATIC		
			POS.1	POS.2	POS.3	POS.1	POS.2	POS.3
SP	Q2411	4MS1	ON	NONE	ON	2-3	N/A	2-1
	Q2412	4MS2	ON	NONE	MOM			
	Q2413	4MS3	ON	OFF	ON		OPEN	
	Q2414	4MS4	MOM	OFF	MOM			
	Q2415	4MS5	ON	OFF	MOM	OPEN	N/A	3-1
	Q2416	4MS6	OFF	NONE	ON			
DP	Q2421	4MD1	ON	NONE	ON	2-3,5-6	N/A	2-1,5-4
	Q2422	4MD2	ON	NONE	MOM			
	Q2423	4MD3	ON	OFF	ON		OPEN	

MOM=MOMENTARY

## POLE OPTIONS

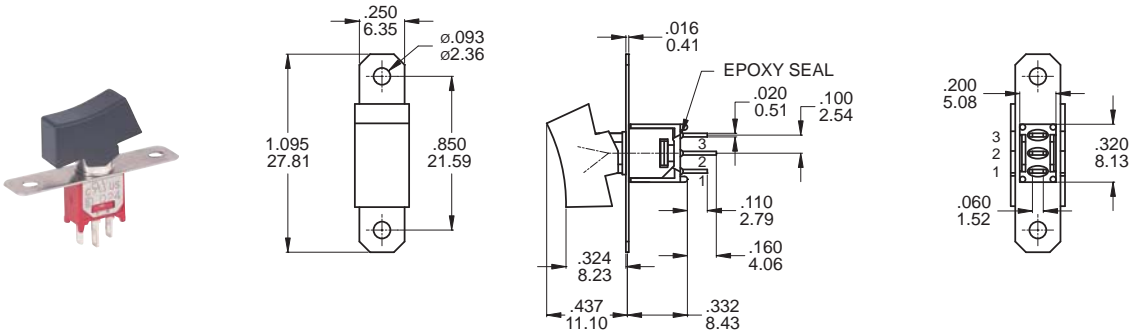

SPDT

Part No. Shown : 4MS1R102M1QES

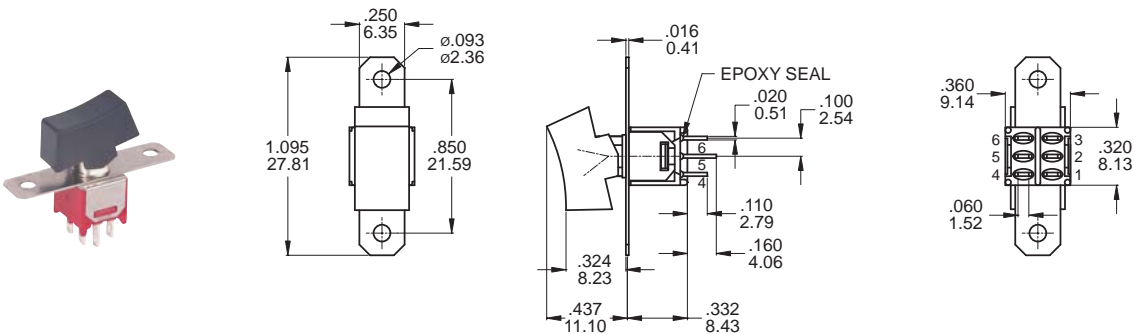

DPDT

Part No. Shown : 4MD1R102M1QES



4M  
Rocker Switches

### ACTUATOR OPTIONS - PANEL MOUNT

R1

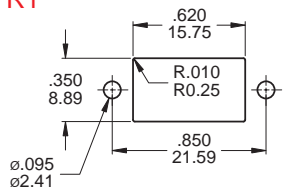

PANEL MOUNTING-R1

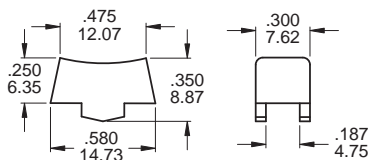

R2

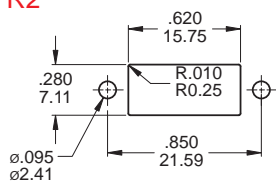

PANEL MOUNTING-R2

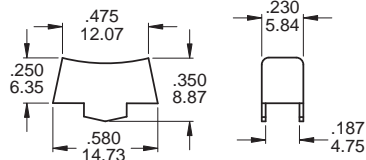

R3

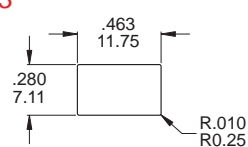

PANEL MOUNTING-R3

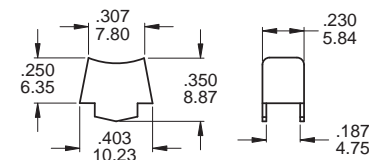

4M  
Rocker Switches

### TERMINATION OPTIONS

M1 Solder lug

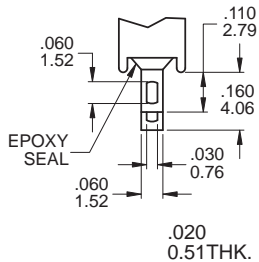

M2 PC Thru-hole

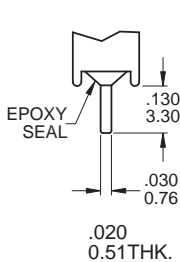

M5 Wire Wrap

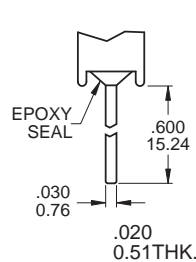

Double Pole

Double Pole

M6

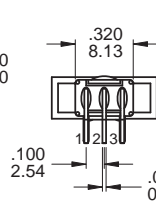
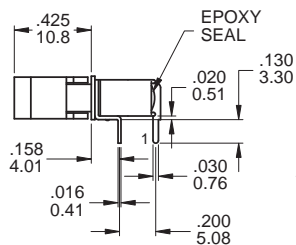
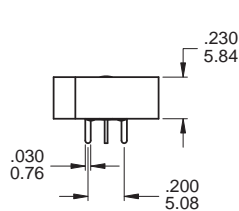

P.C. MOUNTING

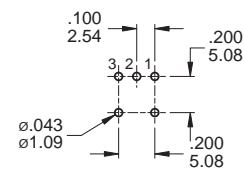

SPDT

Part No. Shown : 4MS1R202M6QES

M6

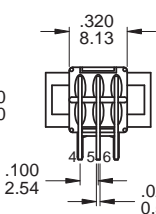
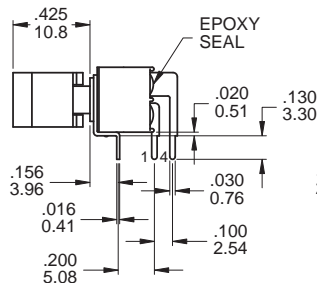
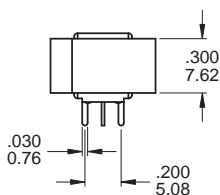

P.C. MOUNTING

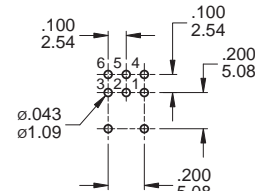

DPDT

Part No. Shown : 4MD1R102M6QES

# 4M Series

Sub-Miniature Rocker Switches

M7

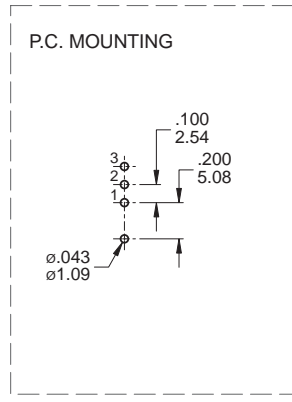
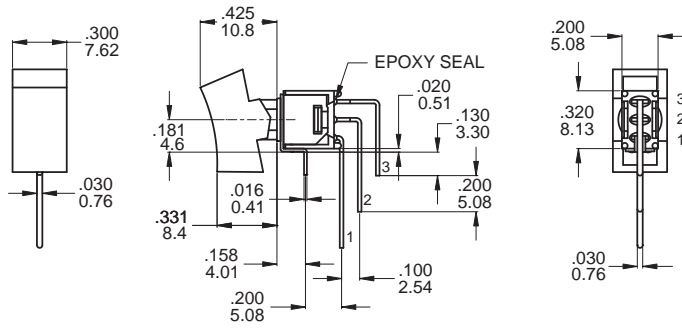

SPDT

Part No. Shown : 4MS1R102M7QES

M7

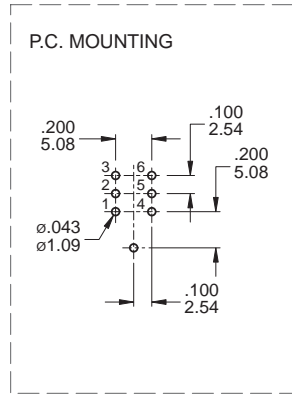
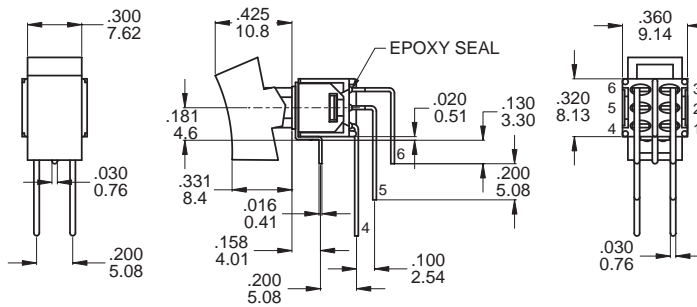

DPDT

Part No. Shown : 4MD1R102M7QES

VS2 - VS3

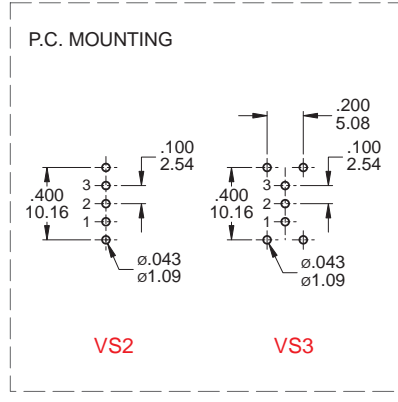
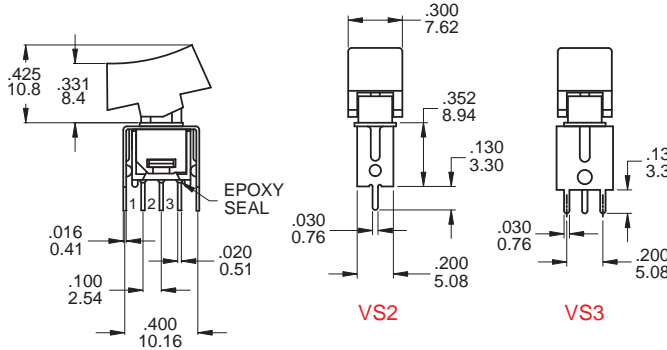

SPDT

Part No. Shown : 4MS1R102VS2QES

VS2 - VS3

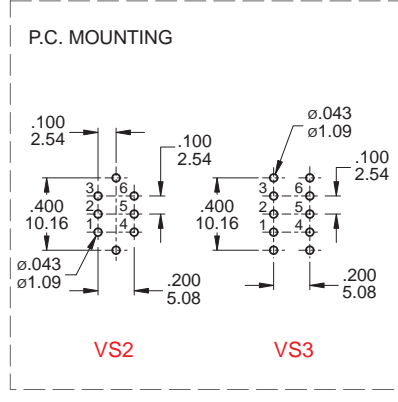
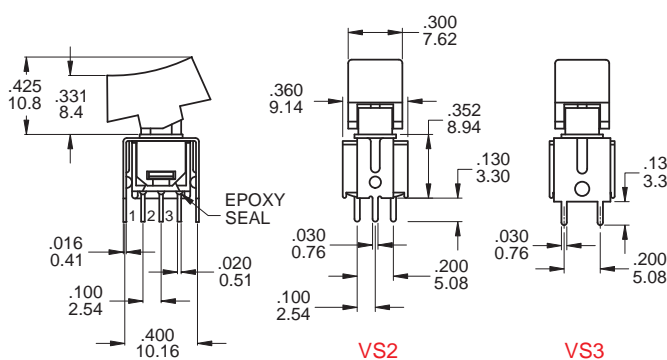

DPDT

Part No. Shown : 4MD1R102VS2QES



4M  
Rocker Switches

## SNAP-IN TERMINATION OPTIONS

M6N



M7N

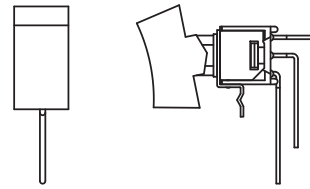

V2N

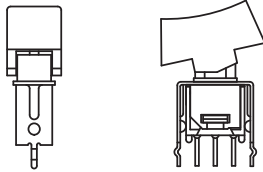

V3N

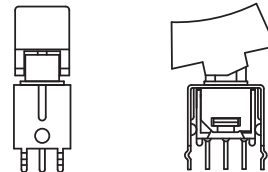

## CONTACT MATERIAL OPTIONS

	CONTACT PLATING	TERMINAL PLATING	RATINGS
Q	Silver	Q = Silver	3 Amps with resistant load @ 120VAC or 28VDC 1 Amps with resistant load @ 250VAC
C	Gold over Silver	C = Gold over silver	
R	Gold	R = Gold	0.4 Volt - Amps ( VA ) max. @ 20V max. ( AC or DC )

## SOLDERING PROCESSES

**MANUAL SOLDERING:** Use soldering iron of 30 watts, controlled at 350°C approximately 5 seconds while applying solder.

**WAVE SOLDERING:** Recommended Soldering Temperature: 270 ± 5°C  
Duration of Solder Immersion: Max 5 sec. (PCB is 1.6mm in thickness)

